

RT3 - 1800kg

Single Axle Braked Trailer



Maximum towable weight of

1800kg

Suitable for most brands of generator up to **50kVA**,* including the following MHM models:

STAGE 5 ENGINE

MGTP 33 SSY/5
MGTP 45 SSY-5

STAGE 3 ENGINE

MGTP 33 SSF
MGTP 45 SSF

Suitable for most brands of generators and other static plant such as tanks, pumps, compressors and other.

Optional extra: Pin hitch

Features Benefits

- Ready for work rolling chassis
- Towable chassis is fully certified and approved and is recorded on a data base in accordance with Regulation 2007/46/EC
- Open frame design
- The design is approved for various load fastening variations
- Chassis is complete with mudguards, brakes and rear lights

- Simply load and secure your equipment and go
- No further testing or certification is required as the standard issue certification satisfies all the elements of trailer legislation and chassis can be legally and safely towed with, or without a payload
- Simply fasten and secure your generator or equipment on and off the chassis with ease
- Choose from ratchet straps or nut and bolts fasteners as both are acceptable
- Trailer is suitable for UK and Ireland highway use

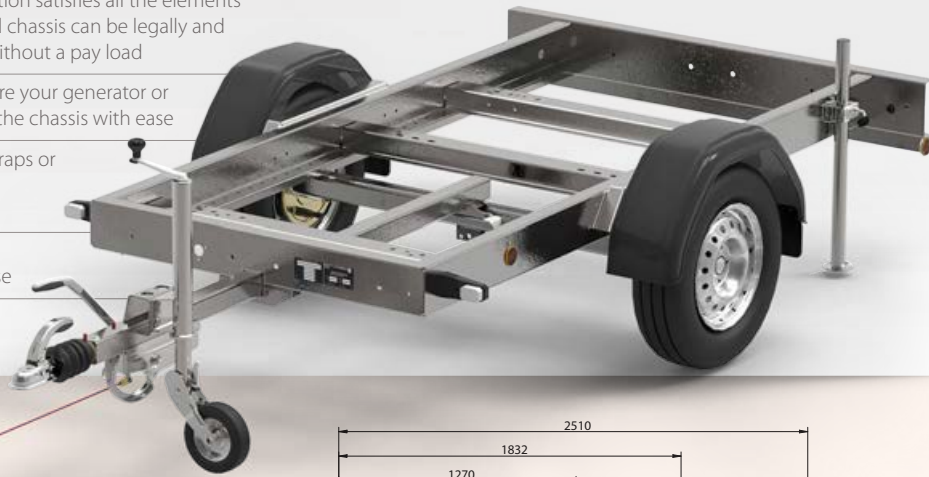

Specification

Tow Hitch Type:	Ball	Suspension:	Yes	Jockey Wheel:	Yes
Wheel Quantity:	2	Brakes:	Yes	Mudguards:	Yes
Wheel Size:	14 inch	Handbrake:	Yes	Tail Lights:	Yes
Tyre Size:	185 R14 C	Breakaway Cable:	Yes		

Dimensions (Trailer)

Length:	3810 mm	Width:	1770 mm	Height:	740 mm
Weight:	300 kg	Max. Load / Bed Weight:	1500 kg		
Max. Bed Area:	2700 mm ²	Max. Gross Vehicle Weight (GVW):	1800 kg		

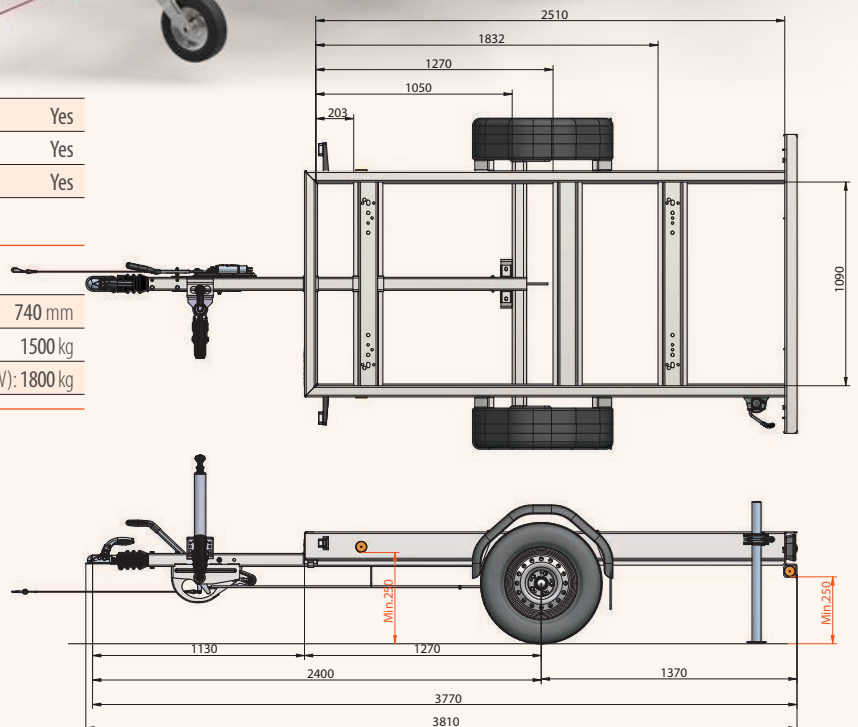
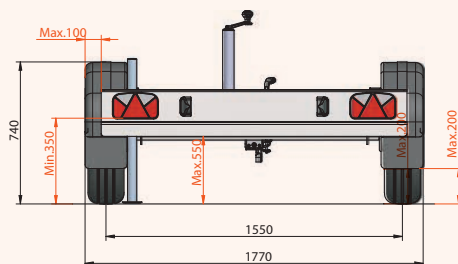

For more details call **MHM TODAY**
on **0808 168 9099**

Email sales@mhmplant.com or visit us at www.mhmplant.com



Designed in the UK,
built in Italy

